

BATTERIA SIGILLATA AGM CON ELEVATO SPUNTO DI AVVIAMENTO  
 AGM MAINTENANCE FREE BATTERY WITH HIGH CRANKING RATE

# ZPC120075



## CHARACTERISTIC / CARATTERISTICHE

Volt	12V	
Capacity / Capacità	20h	110Ah
Reserve capacity at 25A/ Riserva di capacità a 25A	230 min.	
Positive / Positivo	dx	
Short circuit current / corrente costo circuito	5.000Amp	
EN Cranking features / Prestazioni avviamento EN	PHCA 5sce. 27°C	2200Amp
	CCA	1100Amp
	CA	1360Amp
	HCA 27°C	1560Amp
Self-Discharge 25°C Capacity / Autoscarica a 25°C	after 3 month storage	90%
	after 6 month storage	80%
	after 12 month storage	62%
Charge (constant voltage) 25°C	Float	13.6 - 13.8 Volt
	Charge	Max. 33Amp. 14.4 - 14.8 Volt

## CHARACTERISTIC / CARATTERISTICHE

Battery dimensions / Dimensioni batteria			
L/L	W/P	H/A	Tot - H/A
330	173	215	236
Weight / Peso			34.5 Kg
Terminal / Terminali			M10
Plt Qt / Qt per pallet			36
Case / Contenitore			ABS

## HIGH RATE DISCHARGE "EN" CORRENTE DI SPUNTO, "EN" (25°C)

5 sec.	10 sec.	15 sec.	20 sec.
2.200A	2.000A	1.780A	1.590A

## EXTENDED DISCHARGE (25°C) TO 10.02V CORRENTE DI SCARICA FINO A 10.2VOLT (25°C)

5 min	15 min	1 hr	3 hr	5 hr	10 hr	20 hr
414A	208A	69A	29A	19A	11A	5.6A

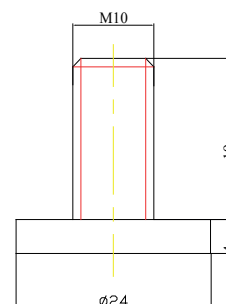
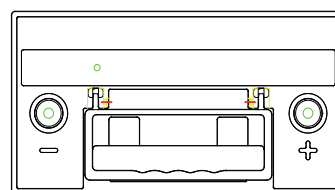
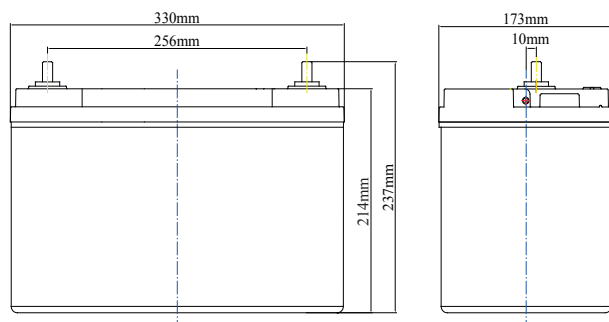

## Terminal Type: DT

This information is generally descriptive only and is not intended to make or imply any representation, guarantee or warranty with respect to any cells and batteries. Cell and battery designs/specifications are subject to modification without notice. Contact U.B.S. UNION BATTERY SERVICE for the latest information.

Le informazioni contenute in questa scheda tecnica sono solo descrittive e indicative, non sono una garanzia. U.B.S. UNION BATTERY SERVICE si riserva il diritto di aggiornarle/modificarle senza preavviso.



[www.unionbatteryservice.it](http://www.unionbatteryservice.it)